

PLASTORX® Fasteners for Plastic Assemblies

Developed to be molded into plastic and replace metal stamping and fastener assemblies, PlasTORX® studs are engineered to provide high resistance to rotation and pull-out, ensuring a high-performance assembly. Its hex-lobular design helps reduce stress risers, so it can be used in materials susceptible to cracking or breaking.



Specifications

Sizes • M4 – M12 (#8 - 1/2")

Lengths • Per customer design

Thread Styles • Machine screw; others as specified

Specials • Completed assemblies available

Applications

Injection-molded thermoplastics and rubber

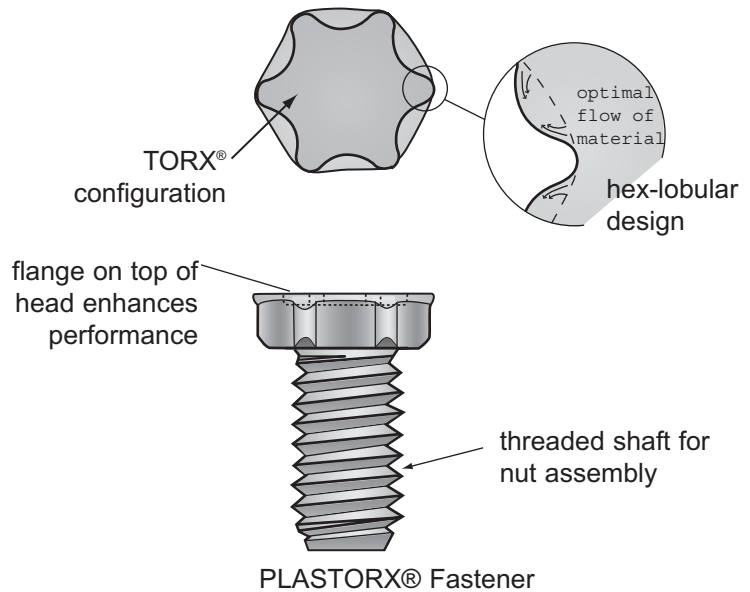

Key Advantages

- Molded directly into application which increases assembly efficiency
- Provides maximum resistance to rotation and pull-out
- Can be used in materials susceptible to cracking

Features & Benefits

Hex-lobular TORX® configuration allows deep lobe engagement

- Increases torsional resistance
- Increases pull-out resistance
- Reduces stress risers

Flange on top of head enhances performance

- Increases pull-out resistance

Threaded shaft for seating nut member

Designed to be molded directly into component or carrier strips, allowing multiple fasteners to be installed at one time

- Reduces assembly time
- Reduces part numbers and associated costs
- Reduces overall costs



www.infastech.com

PLASTORX® and TORX® are registered trademarks of Acument Intellectual Properties, LLC.

This document is for informational purposes only. Infastech makes no warranties, expressed or implied, in this document.

PLASTORX® Fasteners for Plastic Assemblies

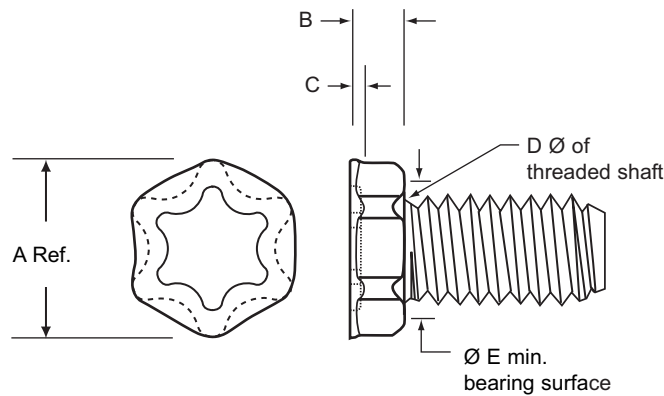

- Contour may vary between lobes within specified dimensions.
- Dimensions shown are for low carbon steel fasteners. For other materials or modified designs, contact an Infastech applications engineer.
- Performance is determined by application material.

Dimensions – Metric

Thread Size	A Ref.	B ±0.13	C ±0.25	D Max.	E Min.	Min. Molded Mat'l Width	Min. Molded Mat'l Height (B + 25%)
M4	9.19	1.84	0.50	0.8	6.30	12.41	2.30
M5	10.95	2.28	0.80	0.8	7.35	14.85	2.85
M6	14.50	3.00	0.80	0.8	10.00	20.25	3.75
M8	16.38	3.68	1.00	1.0	11.30	23.10	4.60
M10	19.99	4.88	1.00	1.0	15.75	28.50	6.10
M12	23.60	6.88	1.14	1.0	18.50	33.90	8.60

Dimensions – Imperial

Thread Size	A Ref.	B ±.005	C ±.010	D Max.	E Min.	Min. Molded Mat'l Width	Min. Molded Mat'l Height (B + 25%)
#8	.362	.072	.030	.031	.248	.489	.090
#10	.431	.090	.041	.031	.289	.585	.113
1/4	.571	.118	.041	.031	.394	.797	.148
5/16	.645	.145	.049	.039	.445	.909	.181
3/8	.787	.192	.049	.039	.620	1.122	.240
1/2	.929	.271	.055	.039	.728	1.335	.339



www.infastech.com

PLASTORX® and TORX® are registered trademarks of Acument Intellectual Properties, LLC.

This document is for informational purposes only. Infastech makes no warranties, expressed or implied, in this document.

Rev 2007