

BUILDING BLOCKS

updates and information
on structural materials



Small Details, Big Consequences

*The Right Type of Fastener Can
Make the Difference Between
Success and Failure*

By Gregg Melvin and Steven H. Miller, CDT

*Gregg Melvin (gmelvin@acument.com)
is a senior applications engineer with Elco
Construction Products. He has been in the
fastener industry for more than 20 years.*

*Steven H. Miller, CDT (steven@chusid.com)
is an award-winning writer and photographer
specializing in issues of the construction
industry. He works with Chusid Associates, a
technical and marketing consultant to makers
of advanced building products.*

Is a tiny detail worth getting right? Does selection of a self-drilling screw merit an engineer's attention?

Over 50,000 self-drilling, self-tapping screws were used to hold slabs of Sardinian granite onto the exterior of the massive Adrienne Arsht Center for the Performing Arts in Miami, Florida. This detail was important enough to warrant specifying a specialized fastener – a selectively-hardened self-drilling screw – instead of the conventional case-hardened fasteners that are widely used in the industry. The reasons for this selection might be surprising.

The Adrienne Arsht Center for the Performing Arts

The Arsht Center is the second largest performing arts center in the US, a 570,000 square foot complex that took five years to construct. Its two main structures, the Sanford and Dolores Ziff Ballet Opera House and the John S. and James L. Knight Concert Hall, include a 2400-seat theater, a 2200-seat concert hall, and a 200-seat studio theater.

What appears to be stone architecture reminiscent of ancient structural methods is actually two layers of very modern design: a backing wall of concrete masonry units (CMUs) and a decorative veneer of granite just 1.4 inches thick. The stone slabs, which averaged 2.5 feet by 4 feet, were made from three different kinds of granite, each requiring slightly different treatment because of variations in thickness and hardness. The wind loads reach 140 psf near the roofline of the structures, which are located in one of only two High Velocity Hurricane Zones under Florida's stringent building codes.

Many of the stone slabs on the Arsht Center exterior, weighing approximately 200 pounds each, are held in place by six ¼-inch structural self-drilling screws.

Hard Facts About Hardening

Screws capable of self-drilling and self-tapping in structural steel are a relatively recent invention, dating back to the 1970s. They drill their own holes and tap their own threads, making the substrate act as the nut that secures the fastener. Hundreds of millions are used around the world every year. Attachment of cladding systems is one of their major uses, but they are also specified in a wide variety of structural applications.

In order to drill into metal, fasteners need an integral drill-point that is harder than the metal being penetrated. This is achieved by first forming the fastener, and then hardening it.

Case-hardening has been the most common method used. Low-carbon steel fasteners are heated in a high-carbon environment, infusing carbon into the outer layer of the steel and creating a hardened shell, or *case*, that is hard enough to drill and tap soft steel. The inner core of the fastener remains softer and more ductile.



Self-drilling, self-tapping screws install quickly using hand-tools. Courtesy of CDC Curtainwall Design Consulting, Inc.

The chief weakness of these fasteners can be, ironically, their hardness. Only the drill tip and the first few threads need to be hardened for self-drilling. The part of a screw used for load-bearing, however, is the main section of the shank, behind the tapping-threads and up to the head. That section has no need of surface hardening; unfortunately, case-hardening is not selective and the entire fastener is treated.

Hardened steel can account for about 25% of the total diameter of the screw. The hardened metal is brittle, not ductile. The effect is that the cross-sectional area of ductile steel can be reduced to 75% or less. In certain situations, as discussed below, that ductility is highly desirable.

Selectively-hardened self-drilling fasteners were developed about 20 years ago. They perform the same function as case-hardened units but avoid surface hardening of the load-bearing portion of the fastener. In selective hardening, only the drill-tip and tapping threads of the unit are hardened. The entire head and the main length of the shank remain softer and more ductile.

The first selectively-hardened fasteners were made of a single piece of special, high-carbon steel alloy. Since carbon is already present in the metal, enrichment in a high carbon chamber is unnecessary. Instead, the fastener tip is passed through a high-voltage induction coil to heat it, hardening it to approximately Rockwell hardness HRC 52, while leaving the rest of the fastener unaffected at Rockwell hardness in the range of HRC 28-34.

Since the Arshat Center was built, the science of selectively-hardened fasteners has continued to advance. First, bi-metallic



Bi-metallic fasteners are also selectively-hardened. The drill-tip and tapping threads are high-carbon steel, fused to a stainless steel shank (left, before coating). The high-carbon steel is hardened, leaving the shank unaffected. The entire fastener is then covered with corrosion-protective/galvanic barrier coating (right). Courtesy of Elco Construction Products.

fasteners were perfected. These highly corrosion-resistant units are made by fusing a high-carbon steel drill-tip and tapping threads onto a 300 series (18-8) stainless steel screw shank. The tip is then selectively hardened. These bi-metallic fasteners soon emerged as the fastener of choice for exteriors and other aggressive environments.

Now, a new generation of fasteners is being introduced that offer much higher loading capacities for a given diameter, allowing significant reductions in the number of fasteners that need to be used for an application. These new fasteners utilize a “super” alloy and a proprietary heating process that results in steel of very high tensile strength, and possessing a specific micro-structure that impedes delayed hydrogen damage. They have been subjected to Rising Step Load testing, in which samples are exposed to a solution with high hydrogen content and put under stress that is periodically increased over a number of hours. The fasteners were stressed up to 70% of their ultimate strength (average 190 ksi/1,310 Mpa) and showed no signs of hydrogen-induced damage. They easily exceed the loading standards for the highest SAE grade, grade 8. Their tested ultimate strength is also higher than the ultimate strength of the highest metric bolt standard, grade 12.9.

These super-high-strength, selectively-hardened fasteners can save money. They are expected to cost approximately 20% more than a selectively-hardened fastener of the type used on the Arshat Center. They can reduce the number of fasteners needed for a given load by up to 40%, a potential savings of 20% on materials cost.

The savings on labor – from installing fewer screws – can multiply the savings on materials several fold. According to Joe Brescia, founder and CEO of Architectural Glass and Aluminum, a leading provider of architectural glazing and cladding, installation gets more expensive the higher you are above ground. Above 10 stories, it costs about \$6.00 for every part installed. This means that, even for an expensive fastener that might cost \$1.00 or \$1.20 each, switching to the super alloy fasteners will save enough on labor to make the fasteners themselves better than free.

Extreme Loading

Under extreme loading situations such as hurricanes, tornadoes, earthquakes, or explosions, the ductility of fasteners becomes a significant issue. These loads are applied impulsively, like a hammer-blow, which can produce a different type of response from gradual or continuous loading in a structural element.



A granite slab is held in place on the exterior of the Arshat Center using a two-part clip assembly. Courtesy of CDC Curtainwall Design Consulting, Inc.

Brittle materials tend to shatter easily under impulsive loading. However, the energy of these loads can be dissipated by ductile structural elements that deform without failing.

With a case-hardened screw, the ductile steel can be diminished to 75% or less of the full cross-sectional area. This makes the fastener more vulnerable to failure under an impulsive load.

In a selectively-hardened screw, the full diameter remains ductile, more likely to stretch than to break under extreme loading. This makes selectively-hardened fasteners a good choice for building enclosure systems for structures in seismic zones and severe weather conditions, buildings that require high security or are considered likely targets for violent attack, and buildings adjacent to potential attack targets.

Surprisingly, however, hurricane-rated fasteners were not required for the cladding on the Arshat Center. The granite slabs were considered a sacrificial veneer that could break and fall off without compromising the weather-proof “skin” of the building.

Designed-In Danger

Instead, selectively-hardened fasteners were chosen because of a little-known but significant issue: due to the use of dissimilar metals in the attachment of the stone slabs, there was a significant risk of hydrogen assisted stress corrosion cracking (HASCC), also known as delayed hydrogen embrittlement. HASCC is a by-product of galvanic reaction, but it only affects steel hardened above certain levels. HASCC can cause the heads of standard quality, properly load-rated, code-approved fasteners to pop off without warning, potentially causing failure of the cladding system. Under test conditions, it can occur in as little as 24 hours. It can also occur in a fastener that has been in service, under load, for 20 years, if moisture is introduced.

continued on next page

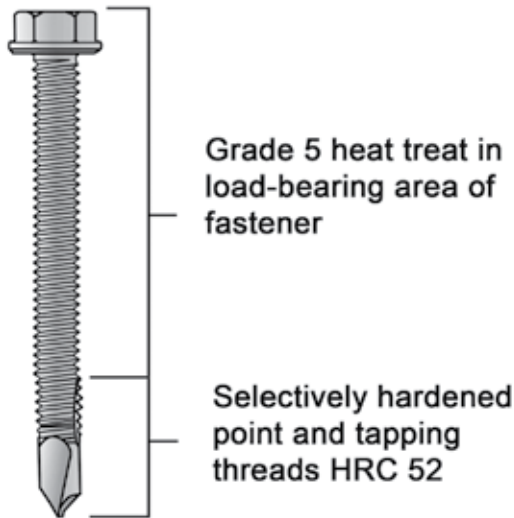

Selectively-hardened fasteners are hardened by passing the drill-tip through a heat-source. The main load-bearing section of the shank remains ductile. Courtesy of Elco Construction Products.

When galvanic reaction occurs, the hydrogen generated by the galvanic cell can cause HASCC. Then the hardened case of the fastener can form micro-cracks right down to the inner, ductile core. Since many of these fasteners have hardness up to HRC 42, even the core is hard enough to be vulnerable to embrittlement and micro-cracking can continue inwards. This can compromise not only the hardened case but a considerable part of the softer core, leaving as little as 25% uncompromised metal. The design load may then exceed the capacity of the screw, causing the head to pop off.

Selectively-hardened fasteners are HRC 34 or less (Grade 5 strength) in the load-bearing portion of the shank and head, and therefore immune to HASCC.

The cladding system of the Arisht Center involved aluminum, stainless steel, galvanized steel, and carbon steel. Given so many possibilities for galvanic reactions and HASCC, with so many metal combinations in a humid environment, selectively-hardened fasteners made sense.

The Arisht Center granite was attached using aluminum anchor clips that fit in kerf-slots on the edges of the stone slabs. Top and bottom courses of stone were attached with running aluminum extrusions the full width of the stone. Intermediate courses have smaller clips, ranging from 8 to 12 inches long.

The anchor clips are two-piece aluminum assemblies. One L-shaped piece is anchored to the CMU backing-wall with $\frac{5}{8}$ -inch stainless steel wedge-bolts, painted with yellow chromate to prevent corrosion. This piece is anchored to the wall before lifting the stone slab into place.

The second piece is screwed to the first with three $\frac{1}{4}$ -inch selectively-hardened screws. This clip-piece has a downward-facing lip that mates with the kerf-slot in the top edge of the stone below it.

The fasteners have a corrosion-preventive coating for long-term structural integrity. If moisture infiltrated the clip assembly, it could set up a galvanic cell between the

For a more complete discussion of HASCC, see Melvin, Gregg and Chusid, Michael, *Making the Right Connections*, The Construction Specifier, Aug. 2008, pg 64.

aluminum clip and an unprotected steel screw. Even though the fastener would be immune to HASCC, galvanic action would cause accelerated corrosion of the aluminum, weakening it at the connection point and possibly resulting in pull-through.

The slab joints are then sealed with a non-staining silicone to protect against wind and rain infiltration.

Costs

Although usually more expensive on a per-unit basis, selectively-hardened fasteners can be less expensive in use than the more conventional case-hardened ones. The drill-tips of conventional fasteners frequently snap off, wasting many screws; this is rare, however, when using selectively-hardened fasteners, yielding overall cost savings. Labor-reduction associated with the new super alloy fasteners is expected to result in even more significant overall savings, especially on high-rise structures.

Summary

When designing structural connections between dissimilar metals, attention must be paid to galvanic reaction. If hardened-steel parts such as self-drilling screws are used for the connection, HASCC is also a possibility. Selectively-hardened fasteners with corrosion-preventative coating can avoid these dangers and protect the integrity of the structure. In exterior applications or aggressive interior environments, bi-metallic or super alloy fasteners are recommended. ■

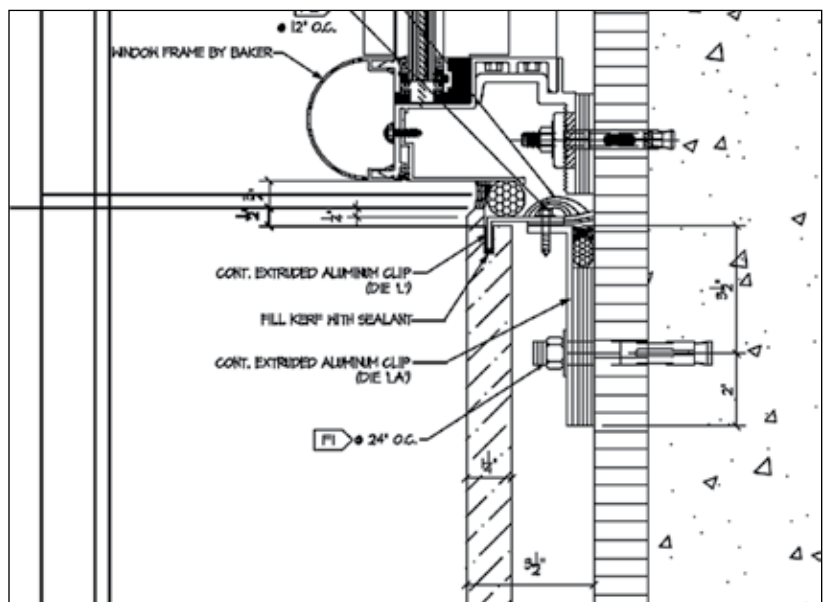

Detail showing the two part clip assemblies, attached to the backing wall with a $\frac{5}{8}$ -inch wedgebolt (F1), and connected with $\frac{1}{4}$ -inch selectively-hardened self-drilling screws (F2). Courtesy of CDC Curtainwall Design Consulting, Inc.